

T5_{tek}

DuraLock

A Lock for Trailer Doors

DL-100 Series

The DuraLock DL-100 series is designed to lock trailer doors offering excellent protection against theft. It is bolted to the door without drilling new holes. Simply undo the 2 nuts holding the door hasp and install the DuraLock using the same holes. When engaged, the DuraLock strong pin secures the handle in place. It unlocks with a key. Designed to meet extreme weather conditions.



Ultra-Rugged Design

The DuraLock is built from an Aluminum block. A solid 7075 aluminum pin secures the handle in place. The pin cannot be cut with a bolt cutter.



High Security Cylinder

The DuraLock uses a high security cylinder with millions of unique key combinations. Keys are extremely difficult to duplicate. Each key has a unique 6-digit serial number that matches the serial number on the face of the cylinder.



Universal Mounting

The DuraLock employs an ingenious mechanism that allows it to replace all hasp sizes. A floating socket can be adjusted to accommodate the mounting hole spacing of the trailer door from 3.75" to 4.75".



Tamper Resistant

When the DuraLock is locked, the tip of the pin is below the surface and cannot be pried open.



Versatile Keying

Cylinders have built-in dust covers and are available with unique individual keys and keys that are keyed the same. Master keys are available upon request.

Mechanical / Design

Dimensions	80 x 155 x 54.4 mm (3.15 x 6.1 x 2.14")
Weight	1,040 g (2.29lbs)
Housing	High-Quality Aluminum Frame, Al 6061-T6 Tensile Strength: 290 MPa (42,061 psi) Hardness: 100HB
Locking Pin	High- Strength Aluminum Solid Rod, Al 7075 Tensile Strength: 524 MPa (76,000 psi) Hardness: 150HB
Anodizing Thickness	15µm
Salt Spray Proof	Yes
UV resistance	1,000hrs per ISO 6581:2010 Standard

Cylinder / Keys

Cylinder Mechanism	Disk Design Anti-pick Anti-drill
Cylinder Material	Zinc Alloy
Number of keys with each DuraLock	3
Master Key	Yes, upon request
Key Material	Brass, Bright Nickel Finish
Key Combination	16,000,000
Security Level	Level C per GA/T 73-2015
Lifetime	30,000 Cycles
Professional Opening Resistance time	270 minutes, unopened
Salt Spray Proof	Yes

Patents

Patents Issued	10,276,061 10,713,613 11,551,498
Patents pending	One Utility One Design

Installation

Installation Summary

The DuraLock is bolted to the Trailer door in place of the hasp. Simply undo the nuts holding the hasp and install the DuraLock using the same holes. No drilling is needed. An adjustable socket makes the DuraLock accommodate the mounting hole spacing of the trailer door from 3.75 – 4.75”

Installation Instructions



Scan this QR code for detailed Installation Manual

Warranty

Manufacturer's Warranty

Two Years from the date of purchase

Certifications

UL	Yes
CE	Yes
Security Level	Level C per GA/T 73-2015

DuraLock Dimensions

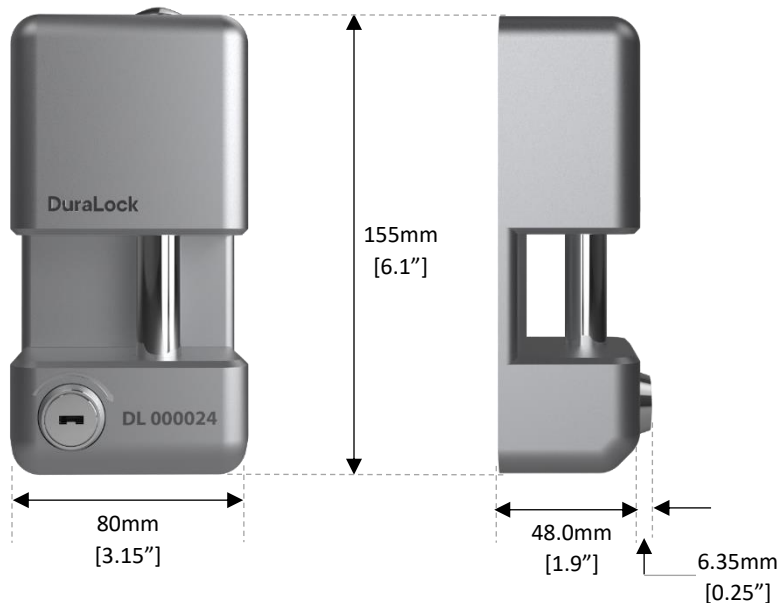

For more information:



T5 tek, Inc.

16731 Trudy Lane
Huntington Beach, CA 92647

www.t5tek.com
sales@t5tek.com
+1 714 398-3115